

SPOTTY

Self-aligning carriage



Key Attributes

Compact and light weight self-aligning carriage with rechargeable battery

Additional Attributes

- Spotty is provided with four drive wheels and with a permanent magnet that secures their grip on the workpiece
- Because of its 6kg weight and of its small dimensions it is very handy and practic to use
- Drive wheels can work on both flat and curves surfaces with an about 800mm minimum diameter
- Two idle rolls make the carriage follow a guidance profile
- Battery power supply allows to work with safeness and without cables
- It is possible to execute either continuous welding or intermittent welding setting the following parameters:
 - Weld length
 - Non-weld length, to be covered at maximum speed
 - Total weld length in cm/min
 - Crater forming and crater filling times

Accessories:

- Kit for welding along external angles
- ON/OFF magnet for stopping carriage
- Additional batteries

Low cost and functional capacity allow a quick economical return

SPOTTY

Self-aligning carriage



CARRIAGE

Weight: 6 kg without battery
Speed range: from 3 to 95 cm/min
Torch holder for torches diameter from 15 to 19mm
Max wheels heating allowed: 70°C
Motor: DC with encoder
Transmission: 4WD
Permanent magnet with release handle

Battery charger AL1820 CV

Feeding: 230 V – 50/60 Hz – 50 W
Charging time: about 120 min
Weight: 0.5 kg

Rechargeable battery

Li-ion: 4 Ah – 18 V
Weight: 0.6 Kg

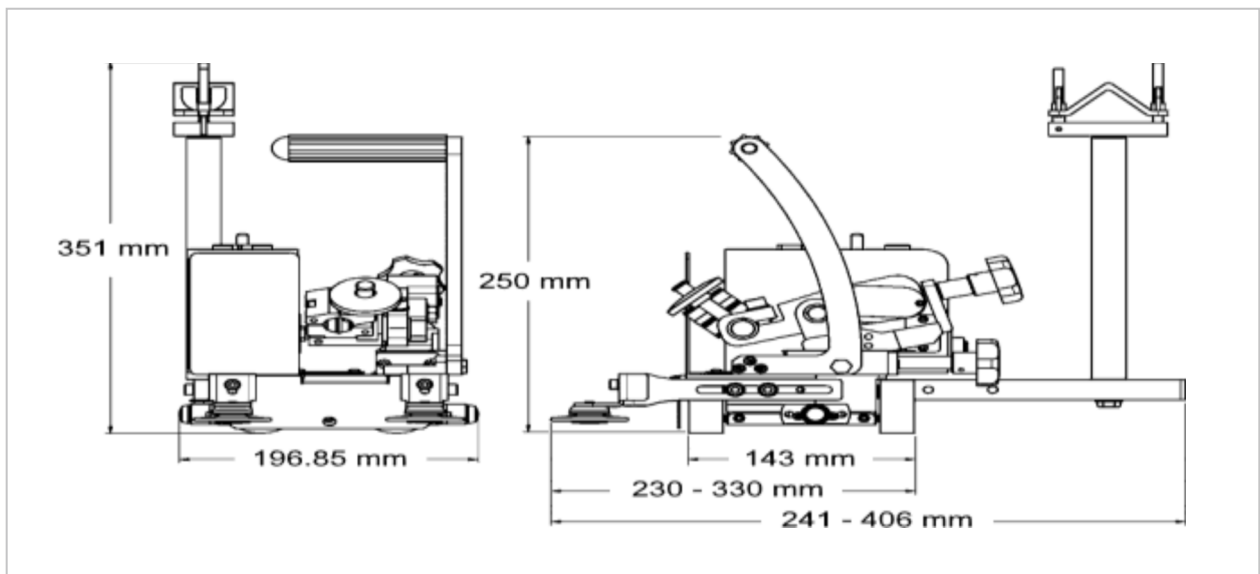

SPOTTY

Self-aligning carriage

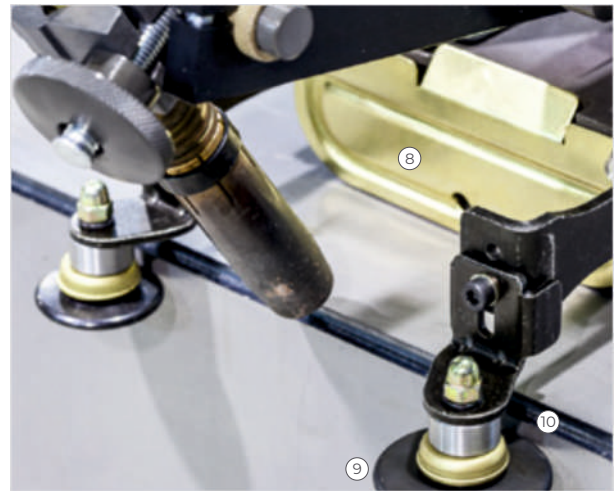

ADJUSTMENTS, DEVICES AND CONTROLS

1. Angular torch adjustment
2. Horizontal torch adjustment
3. Limit-switch
4. Torch holder extension (optional for welding along external angles)
5. Handle with releasing system for permanent magnet
6. Battery
7. Torch cable support (optional)

8. Welding spatter wheels/shielding plate
9. Guidance idle rolls
10. Spacer (optional for welding along external angles)

1. Digital display. It shows

- Speed in cm/min
- Weld length
- Non-weld length
- Total weld length
- Starting delay from arc triggering
- Crater filler

2. Parameters adjustment knob

1. Pressing the knob the user can change parameter to be set
2. Rotating the knob the user will choose the value
3. Direction switch
4. Weld ON/OFF
5. Start
6. Line lamp
7. Torch connector



SPOTTY

Self-aligning carriage



BASIC EQUIPMENT AND ACCESSORIES

1. Carriage provided with torch holder and limit-switches
2. Nr.118V Li-ion, 4 Ah chargeable battery
3. Nr.1 battery charger
4. Allen keys set



OPTIONAL ACCESSORIES

1. SPT-PTC torch cable support
2. SPT.165 ON/OFF magnet for limit-switches
3. SPT-ANG kit for welding along external angles, consisting of torch holder extension arm plus two spacers for the idle rolls.

HOW TO USE THE CARRIAGE - EXAMPLES



Corner inner welding with drive wheels on the horizontal plate of the workpiece.

Vertical plate acts as a guide.



Corner outer welding with drive wheels on the vertical plate of the workpiece.

Horizontal plate acts as a guide. this case occurs when the horizontal plate is narrow.



Corner outer welding with drive wheels on the horizontal plate of the workpiece.

Vertical plate acts as a guide. It is necessary SPT-ANG kit.



Corner outer welding with drive wheels on the circular wall of the workpiece.

Minimum workpiece diameter 800mm.

1. SUPPLY OBLIGATION ARRANGEMENT

The following general terms of business are always to be considered applicable to every order made by the buyer. Therefore, any supply clause written by the buyer on his orders or any other document given to the seller, which may result to be conflicting with the present general conditions, will be considered not written. The buyer has to forward the orders to the seller in writing. The seller reserves the authority to accept telephone and verbal orders. The order is to be considered executed when the buyer receives the written acceptance of the same (order confirmation) by the vendor or, in the absence thereof, automatically 15 days after the order receipt by the seller. All offers and prices are just an indication and are not binding. Therefore the seller considers himself to be bound only to what is declared in his order confirmations.

2. TERMS FOR DELIVERY

The delivery dates indicated by the seller as well as the ones written on the buyers' orders have to be considered just as an indication and are not binding and are subject to the punctual supply by the buyer of all the specifics, to the variations due to the availability of the goods with the suppliers or to reasons of force majeure: delays in the delivery due to said availability variations are not attributable to the seller, who is not in duty bound to the compensation for damages suffered by the buyer. Reasons of force majeure have also to be considered the accidents (industrial injury, disease, etc) and any other circumstances which may cause a total or partial job reduction, as well as the lack of raw materials, troubles with transportation, etc. The seller reserves the authority to suspend the delivery of the goods if the buyer has not seen to the payment of the invoices relative to other supplies whose terms of payment are overdue. The goods are understood as being delivered for all intents and purposes to the buyer from the time they were picked up by the carrier or the buyer himself at the seller's warehouse.

3. PAYMENT AND TERMS OF PAYMENT

The payments have to be made to the seller's domicile and in accordance with the established conditions. In the event of a delay, the due amounts of money will automatically imply the charge of interests based on the official discount rate plus 5 points. In the event of a nonpayment, the buyer is to be considered in default without the necessity of any formal notice by the seller. The presence of possible faults and/or defects in the products does not excuse the buyer for suspending the payment of the invoices. Should the client suspend and/or delay the payments, the seller may suspend the supplies, with the authority to consider the contract automatically terminated by rights and to demand for damages.

4. WARRANTY

CARPANO EQUIPMENT guarantees the products for a period of 24 months starting from the delivery date, for a daily work cycle of 8 hours. The warranty is intended ex works CARPANO EQUIPMENT. CARPANO EQUIPMENT guarantees the performance of its products in accordance with the instructions written in the relative manuals. For the products based on job orders, the warranty is pertaining to the specifics agreed with the client.

5. VOID WARRANTY

In case of any tampering or unauthorized intervention the warranty shall be deemed void.

6. LIABILITY FOR DAMAGE

The seller's liability is limited only to the obligations above and it's expressly agreed that the seller does not accept any liability for damages resulting from any cause connected with the use and utilization of the sold products.

CARPANO EQUIPMENT is not responsible and for no reason whatsoever may the expenses be charged for:

- Machine downtime.
- Direct or in direct damage due to the non-operation of the equipment.
- Working hours spent to solve possible problems on the equipment.

Cont...

SPOTTY

Self-aligning carriage

7. RESERVATION OF OWNERSHIP

Until the payment in full of any credit resulting from business relations has taken place, included any additional credit and until the payment of bills and cheques has been made, the property in the goods remains in the seller.

8. COMPETENT COURT

It's established that the court of Bologna will be the sole competent court for every dispute relative to this contract.

9. APPLICABLE LAWS

The applicable law is the Italian law.

WARRANTY DETAILS

Duration: One year from the commissioning date. ADOR WELDING LIMITED ensures new equipment sold through Plant/Area Offices/Authorized Distributors is free from defects in materials and workmanship, performing as per applicable specifications.

Engine Warranty: All engines and engine accessories are covered by their respective manufacturers and are not included in this warranty.

Cable Wear: ADOR is not liable for wear and damage to cables caused by flexing and abrasion. Users must regularly inspect cables for wear and address any issues before cable failure occurs.

Design and Specification Changes: ADOR WELDING LIMITED reserves the right to modify designs and specifications without prior notice due to continuous development.

Customer Care: Supported by a dedicated customer care package.



ADOR WELDING LIMITED

Corporate Marketing Office: Survey No.147 / 2B+3, Near Khandoba Mandir, Akurdi Chowk, Chinchwad, Pune - 411019. Maharashtra. India.

☎ 1800 233 1071 ✉ cmo@adorians.com 📞 +91 20 40706000

